



RSF Elektronik

www.rsf.at

MS 15

EXPOSED LINEAR ENCODERS
WITH HOMING AND LIMIT FUNCTION





SPECIAL FEATURES

- Online signal stabilization
- Display of the signal quality directly at the scanning head via 3-coloured LED function
- Permanent control of the signals over the whole measuring length
- High quality of the signals due to singlefield scanning
- Homing and limit function
- Reference mark position customizable

TERM EXPLANATIONS

Grating period

A grating is a continuous series of lines and spaces printed on the graduation carrier. The width of one line and one space is called the period of the grating. The lines and spaces are accurately placed on the graduation carrier.

Signal period

When scanning the grating, the scanning head produces sinusoidal signals with a period equal to the grating period.

Interpolation

The sinusoidal signal period can be electronically divided into equal parts. The interpolation circuitry generates a square-wave edge for each division.

Measuring step

The smallest digital counting step produced by an encoder.

Yaw angle, pitch angle, roll angle, displacement, gap tolerance

Mounting tolerances of the scanning head relative to the graduation carrier.

Reference pulse (reference mark)

There is an additional track of marks printed next to the grating to allow a user to find an absolute position along the length of the graduation carrier. A one increment wide signal is generated when the scanning head passes the reference mark on the graduation carrier.

This is called a "true" reference mark since it is repeatable in both directions. Subsequent electronics use this pulse to assign a preset value to the absolute reference mark position.

Error signal (\overline{US})

This signal appears when a malfunctioning encoder generates faulty scanning signals.

Online signal stabilization (HSP)

During moving the amplitude, offset-error, amplitude differences and phase shift error are measured and stabilized cyclic.

Abbe error

Measuring error due to lateral distance between the measuring system and the machining level.

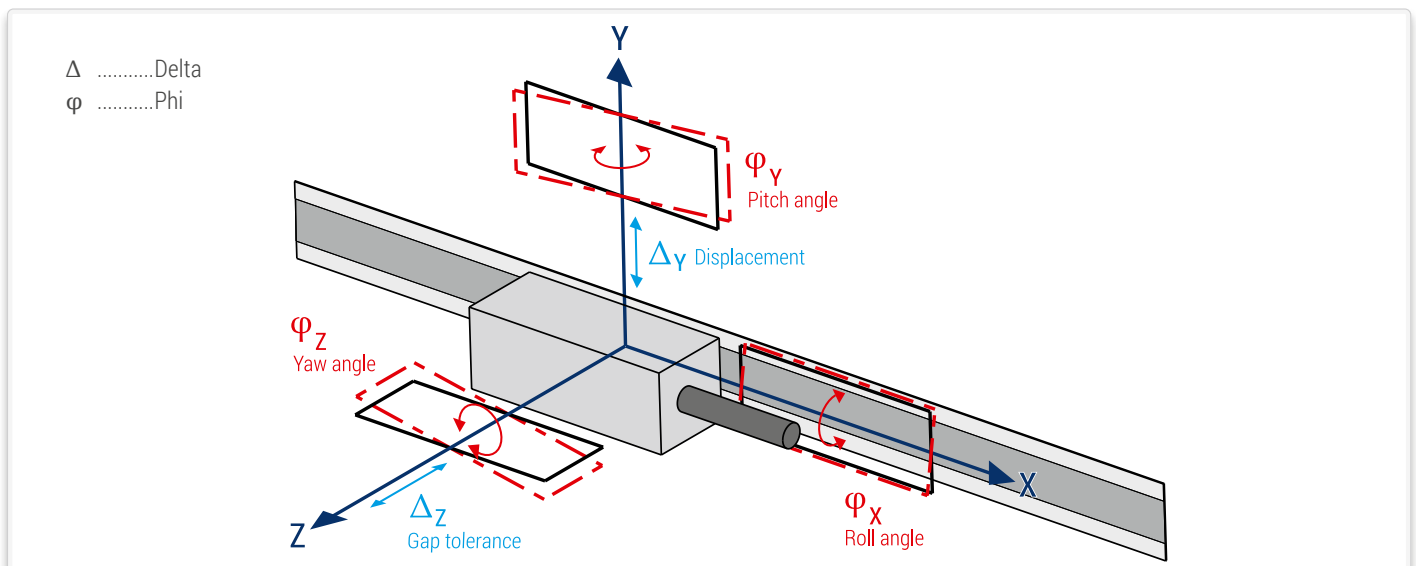

PERFORMANCE CHARACTERISTICS

- CONTAMINATION RESISTANCE
- IMMUNITY AGAINST AGING AND TEMPERATURE CHANGES
- HIGH PERMISSIBLE TRAVERSING SPEED
- EASY MOUNTING
- SMALL DIMENSIONS
- NO MECHANICAL BACKLASH
- NO FRICTIONAL FORCE
- REFERENCE MARKS REPEATABLE FROM BOTH TRAVERSING DIRECTIONS
- TWO SEPARATE SWITCH SIGNALS
- RESOLUTION: $10\ \mu\text{m} - 0.05\ \mu\text{m}$



MS 15 MEETS ALL THESE REQUIREMENTS!

SCANNING PRINCIPLE

The model MS 15 incremental linear encoder system works with the photoelectric measuring principle and a **singlefield reflective scanning method**.

The regulated light of an infrared LED is collimated by a condenser lens and passes through the grid of the reticle. After being reflected from the graduation carrier, the infrared LED generates a periodic intensity distribution on the structured sensor.

The sensor generates high quality sinusoidal signals which are highly insensitive to possible contaminations.

The regulation of the LED ensures a constant signal amplitude, guaranteeing stability in the case of temperature fluctuations and with long-run operation.

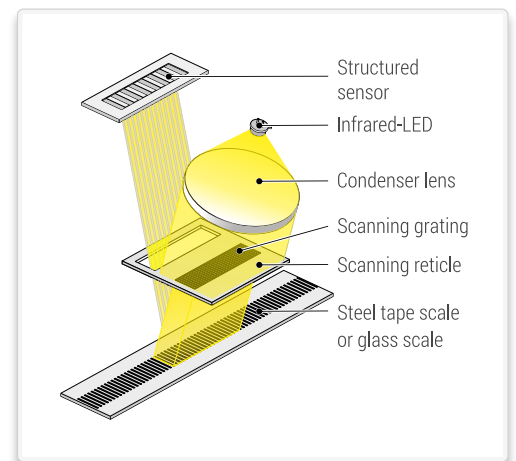

REFERENCE MARKS

Principle of the standard reference marks



Principle of the distance-coded reference marks

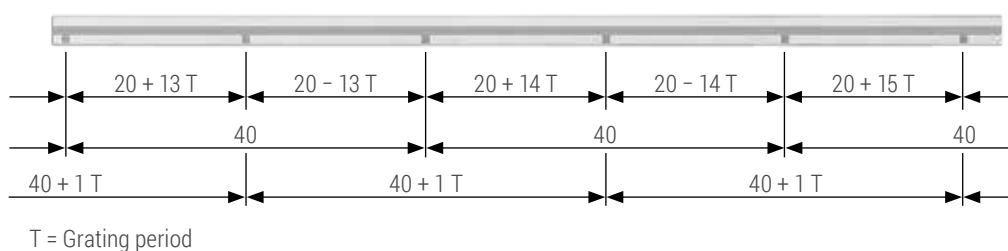

ACCURACY DEFINITION

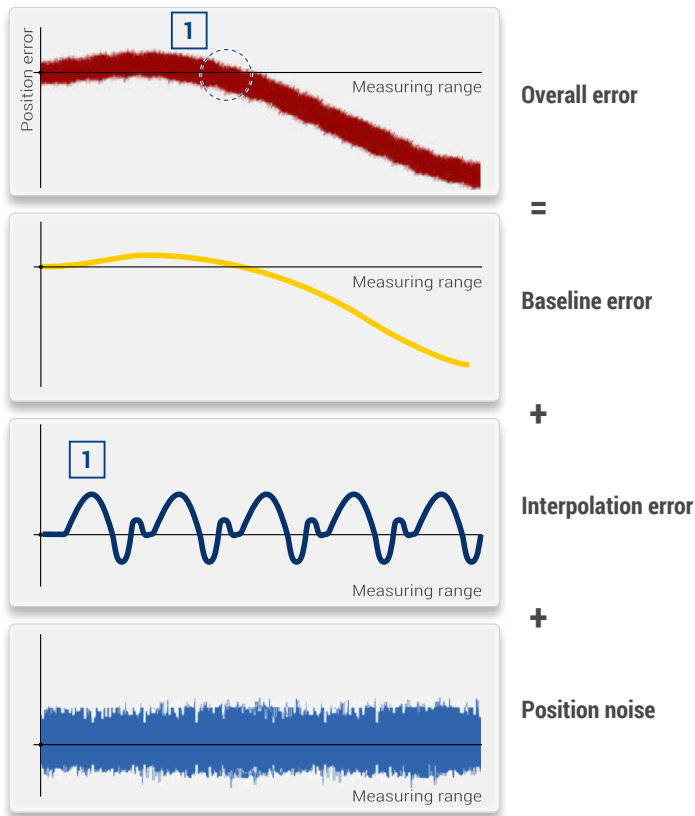

The accuracy of a linear encoder is mainly determined by the baseline error of the graduation carrier, the interpolation error of the optoelectronic scanning and the position noise.

The baseline error is the error of the graduation carrier identified in a measurement room under optimum conditions, along a determined measuring length, without any interpolation error and position noise.

The indicated accuracy grade represents the maximum possible baseline error. It is calculated within any section with a maximum length of one meter.

Effect of contamination on the quality and amplitude of scanning signal

Graduation carrier contaminated by fluids, dust, particles, fingerprints etc.

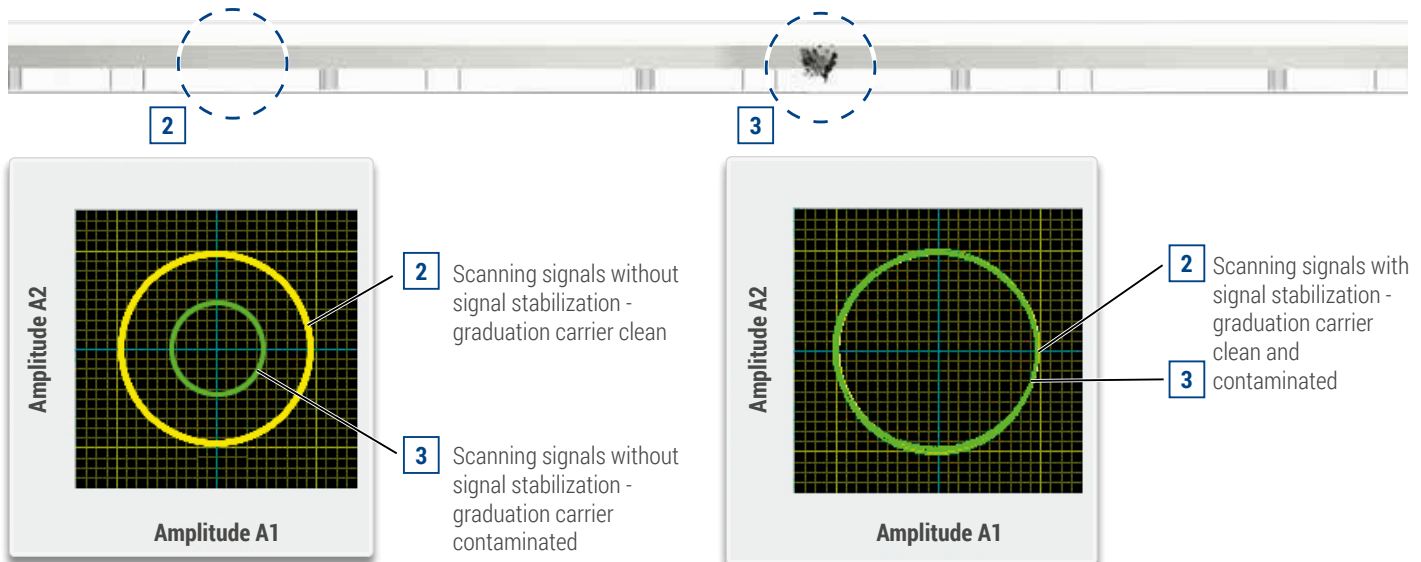

Effect of contamination on the interpolation error

Graduation carrier contaminated by fluids, dust, particles, fingerprints etc.

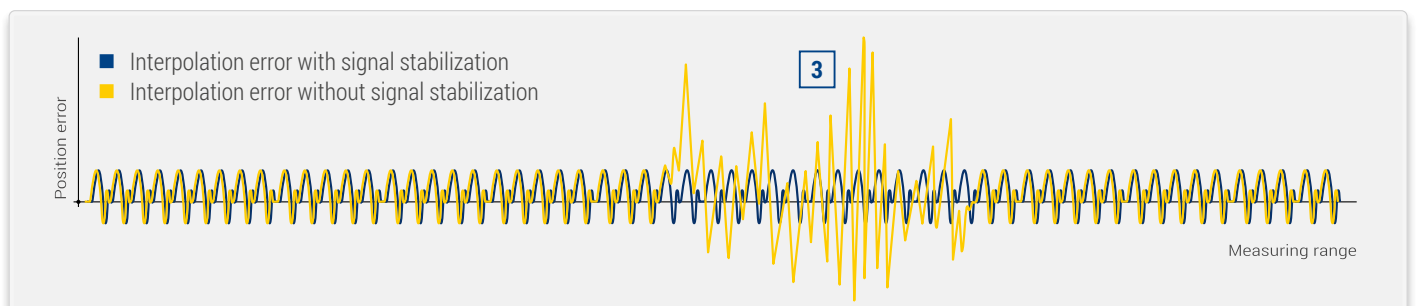

SHIELDING, PIN ASSIGNMENT

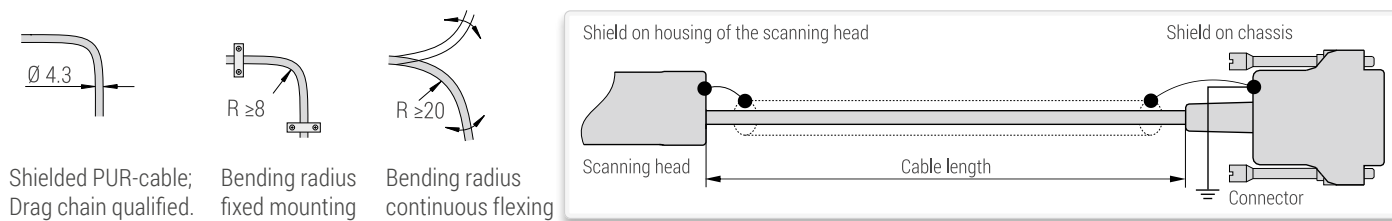

D-sub connector, male, 15-pin

Pin	1	2	3	4	5	6	7	8	9	10	11	12	13	14	15
Sinusoidal voltage signals 1 Vpp	Test**	0 V Sensor	Occupied	RI-	A2-	A1-	V+ Sensor	V+	0 V	S1***	S2***	RI+	A2+	A1+	nc
Square-wave signals via line driver	Test*	0 V Sensor	US	RI	T2	T1	V+ Sensor	V+	0 V	S1***	S2***	RI	T2	T1	nc

- * Test = analog signal switch-over for set-up. By applying +5 V to the test pin, the test signals (sinusoidal micro-current signals 11 µApp) are switched to the output connector.
- ** Test = analog signal switch-over for set-up. By applying +5 V to the test pin, the NOT corrected test signals (1 Vpp) are switched to the output connector.
- S1, S2 = switch signals.
- *** Version without switch signals (version K) = without function.
- Sensor: the sensor pins are bridged in the chassis with the particular power supply.
- The shield is connected with the chassis.
- Pins or wires marked "occupied" or "nc" must not be used by the customer.

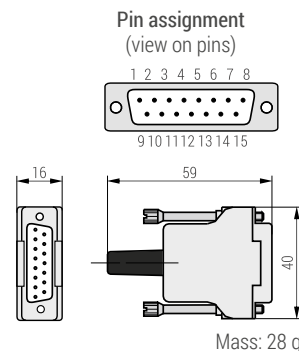

Effect of the scanning head gap on the signal amplitude

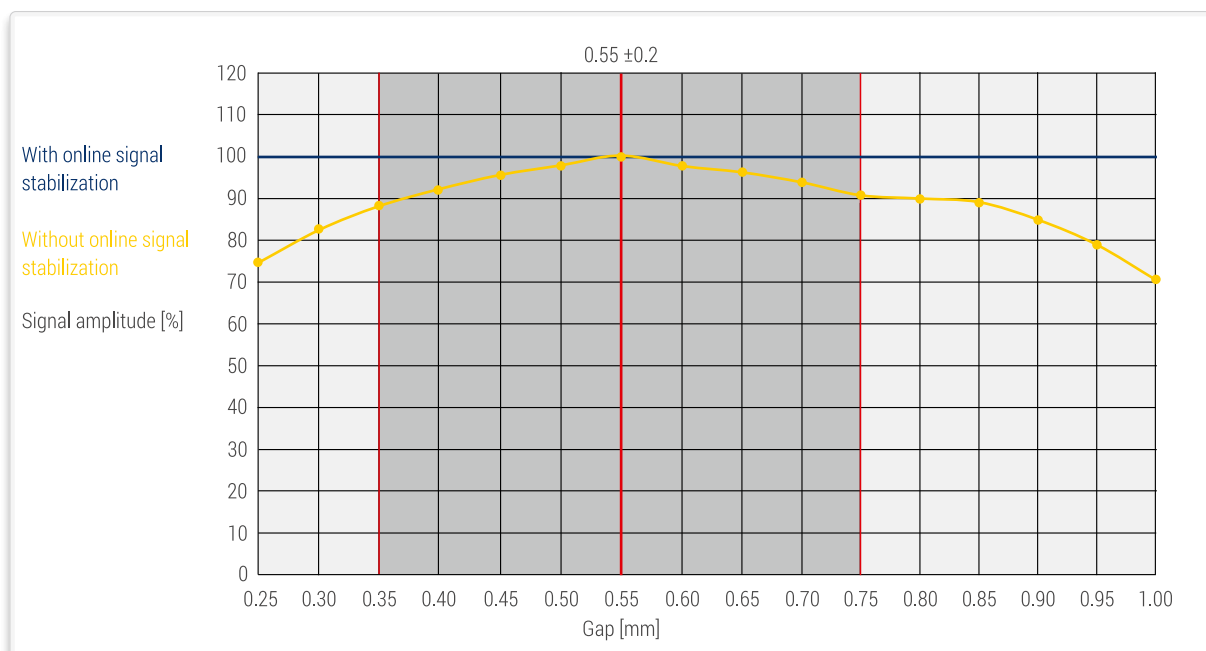

INTERFACES

SINUSOIDAL VOLTAGE SIGNALS 1 VPP

(drawing shows "positive counting direction")

Power supply: +5V ±10 %, max. 160 mA (unloaded)

Track signals (differential voltage A1+ to A1- resp. A2+ to A2-):

Signal amplitude 0.6 Vpp to 1.2 Vpp; typ. 1 Vpp

(with terminating impedance $Z_0 = 120 \Omega$ between A1+ to A1- resp. A2+ to A2-).

Reference mark (differential voltage RI+ to RI-):

Square-wave pulse with an amplitude of 0.8 up to 1.2 V; typical 1 V

(with terminating impedance $Z_0 = 120 \Omega$ between RI+ to RI-)

Advantage:

- High permissible traversing speed with long cable lengths possible.

Voltage signals (1 Vpp)

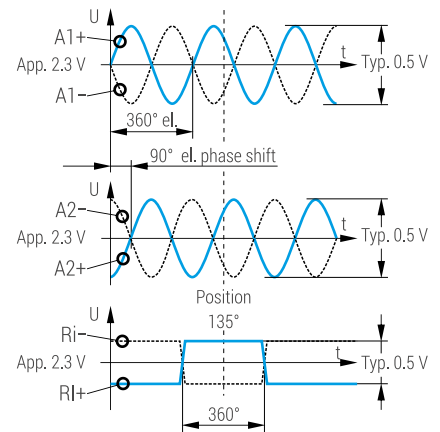

SQUARE-WAVE SIGNALS

(drawing shows "positive counting direction")

With the integrated interpolation electronics (for times -1, -5, -10, -20, -25, -50, -100 or -200) the photoelement output signals are converted into two square-wave signals that have a phase shift of 90°.

The output signals are „differential“ via line driver (RS 422). One measuring step reflects the measuring distance between two edges of the square-wave signals.

The controls/DRO's must be able to detect each edge of the square-wave signals. The minimum edge separation a_{min} is listed in the technical data and refers to a measurement at the output of the interpolator (inside the scanning head). Propagation-time differences in the line driver, the cable and the line receiver reduce the edge separation.

Propagation-time differences:

Line driver: max. 10 ns

Cable: 0.2 ns/m

Line receiver: max. 10 ns (referred to the recommended line receiver circuit)

To prevent counting errors, the controls/DRO's must be able to process the resulting edge separation.

Example:

$a_{min} = 100 \text{ ns}$, 10 m cable

$100 \text{ ns} - 10 \text{ ns} - 10 \times 0.2 \text{ ns} - 10 \text{ ns} = 78 \text{ ns}$

Power supply: +5V ±10%, max. 160 mA (unloaded)

Advantages:

- Noise immune signals.

- No further subdividing electronics necessary.

Square-wave signals „differential“

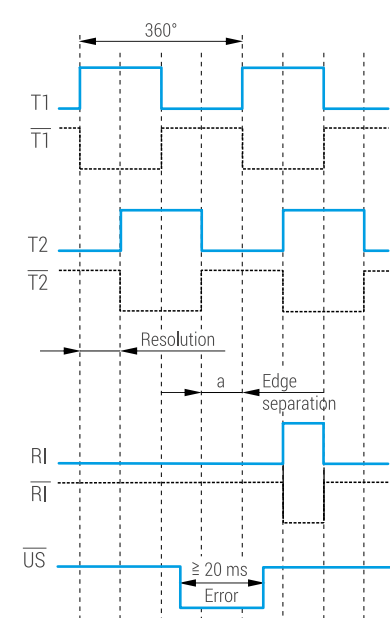

Recommended line receiver circuit

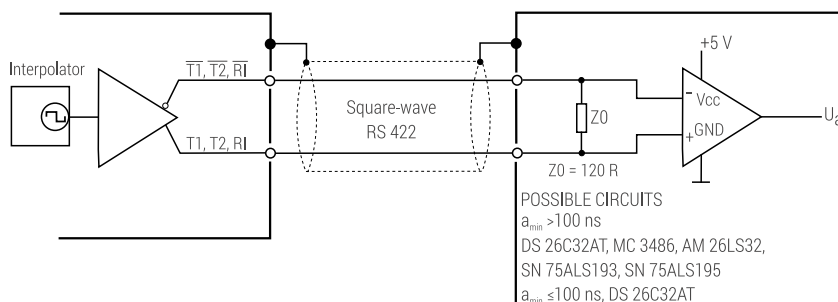

Counting direction

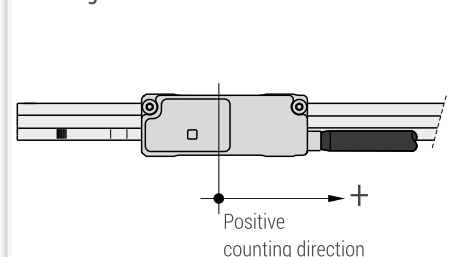

SWITCH SIGNAL OUTPUT

For individual special functions there are two additional switch tracks on the steel tape scale.
The switching point position can be chosen by the user by placing self-adhesive covering tapes.

VERSION H

TTL output (active high)

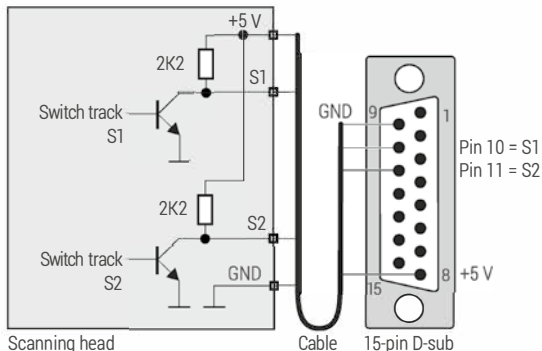

S1, S2 = TTL output
 $I_{SOURCE} = 1 \text{ mA}$ (high level $> 2 \text{ V}$)
 $I_{SINK} = 20 \text{ mA}$ (low level $< 0.8 \text{ V}$)



VERSION Z

Open collector output (active high impedance)

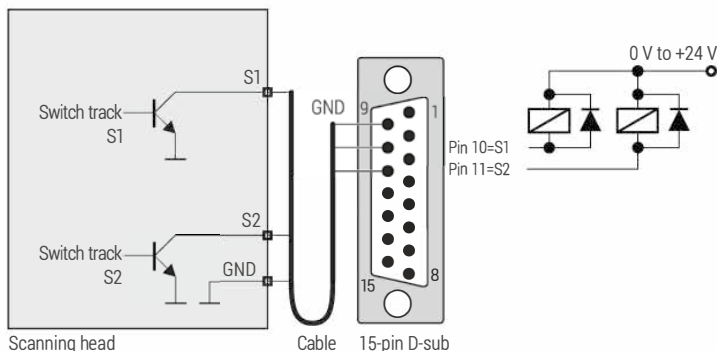

S1, S2 = open collector output
 $I_{SINK} = 20 \text{ mA}$ (low level $< 0.8 \text{ V}$)



VERSION L

TTL output (active low)

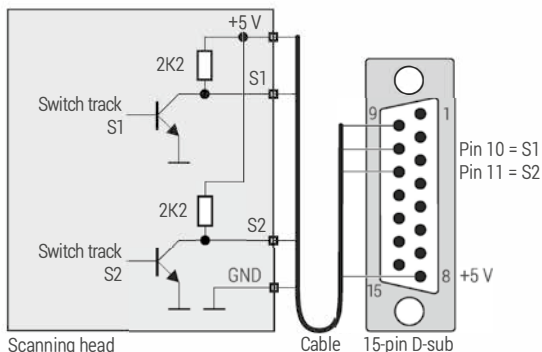

S1, S2 = TTL output
 $I_{SOURCE} = 1 \text{ mA}$ (high level $> 2 \text{ V}$)
 $I_{SINK} = 20 \text{ mA}$ (low level $< 0.8 \text{ V}$)



VERSION C

Open collector output (active low)

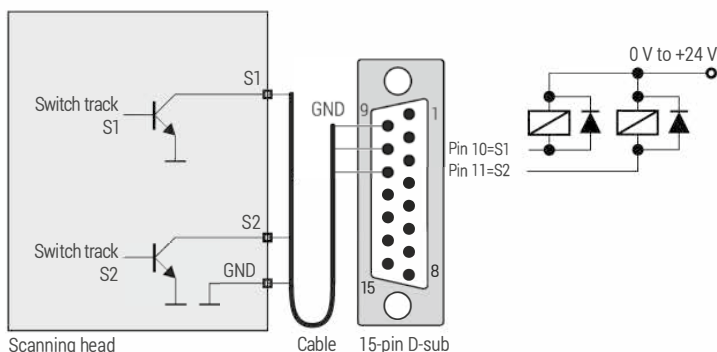

S1, S2 = open collector output
 $I_{SINK} = 20 \text{ mA}$ (low level $< 0.8 \text{ V}$)



TECHNICAL DATA

SCANNING HEAD

Model	AK MS 15 1 Vpp	AK MS 15 TTLx1u	AK MS 15 TTLx5	AK MS 15 TTLx10	AK MS 15 TTLx20	AK MS 15 TTLx25	AK MS 15 TTLx50	AK MS 15 TTLx100	AK MS 15 TTLx200
Interface	~	⌋	⌋	⌋	⌋	⌋	⌋	⌋	⌋
Measuring step [μm]	Depending on external interpolation	10.00	2.00	1.00	0.50	0.40	0.20	0.10	0.05
Integrated interpolation	--	Times 1	Times 5	Times 10	Times 20	Times 25	Times 50	Times 100	Times 200
Max. velocity [m/s]	10.00	10.00	6.40	3.20	2.40	1.92	1.92	0.96	0.96
Max. output frequency	250 kHz	--	--	--	--	--	--	--	--
Edge separation a _{min}	--	500 ns	300 ns	300 ns	200 ns	200 ns	100 ns	100 ns	50 ns
Interpolation error with signal stabilization	Typical ±65 nm (peak-peak)								
Electrical connection	Cable, 0.5 m, 1 m or 3 m with D-sub connector, male, 15-pin								
Voltage supply	+5 V ±10 %								
Power consumption	Max. 880 mW (without load)								
Current consumption	Max. 160 mA (without load)								
Vibration 55 Hz – 2000 Hz Shock 8 ms	≤ 150 m/s ² (EN 60 068-2-6) ≤ 750 m/s ² (EN 60 068-2-27)								
Operating temperature Storage temperature	0 °C to 50 °C -20 °C to 70 °C								
Mass	Scanning head: 12 g (without cable), cable: 30 g/m, connector: D-sub connector: 28 g								

GRADUATION CARRIER

Model	MB MS 15 MK	MS 15 MP	MS 15 GK	MS 15 BK
Graduation carrier	Steel tape scale	Steel tape scale	Glass scale	Glass ceramic scale
Coefficient of linear expansion	$\alpha \approx 10 \times 10^{-6}/K$	$\alpha \approx 10 \times 10^{-6}/K$	$\alpha \approx 8.5 \times 10^{-6}$	$\alpha \approx 0 \times 10^{-6} / K$
Grating period	40 μm	40 μm	40 μm	40 μm
Accuracy grades *	±5, ±15 μm/m	±5, ±15 μm/m	±3, ±5 μm/m	±3, ±5 μm/m
Non-linearity *	±3 μm/m	±3 μm/m	±3 μm/m	±3 μm/m
Baseline error	≤ ±0.75 μm/50 mm (typical)	≤ ±0.75 μm/50 mm (typical)	≤ ±0.30 μm/10 mm	≤ ±0.30 μm/10 mm
Measuring length ML	20 000 mm	20 000 mm	3140 mm	1920 mm **
Reference marks	Standard: 50 mm equidistant / Position selectable by customer / Distance-coded on request			
Mass	17 g/m	90 g/m + 2 g clamping	55 g/m	57 g/m

* At 20 °C

** Longer lengths on request

CONFORMITIES AND CERTIFICATIONS

RoHS	2011/65/EU, 2015/863/EU
EMV	2014/30/EU
Product-Certifications	UL, CSA, EN, IEC 61010-1

MS 15 MK

- Steel tape scale with adhesive tape



Dimensions, mounting tolerances:

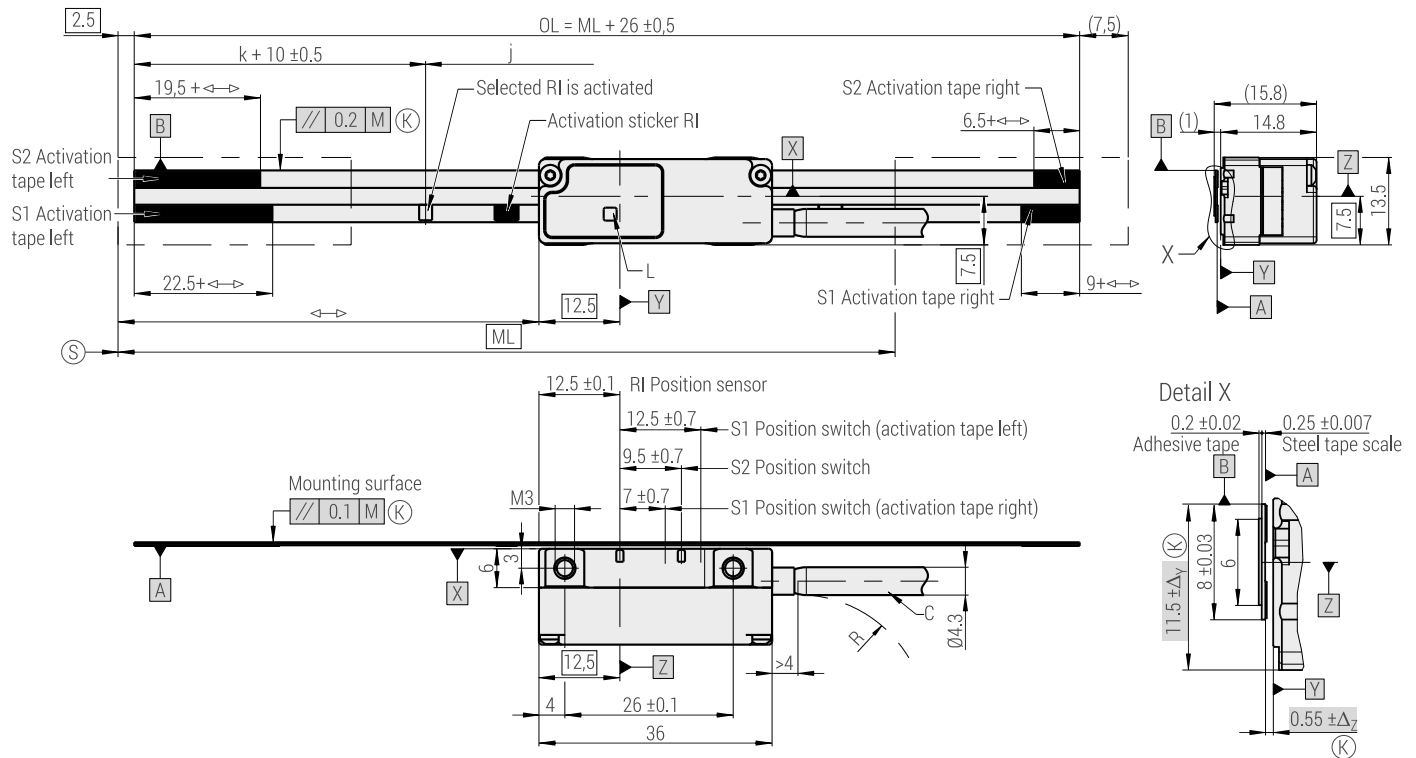

M = Machine guideway

ML = Measuring length

OL = Overall length

↔ = 0...ML

RI = Selectable reference mark(s)

k = Any position of the selected reference mark starting from the beginning of the ML

j = Additional reference marks separated by $n \times 50$

C = Cable

(K) = Required mating dimensions

L = LED function control

R = Bending radius: stat. $R \geq 8$ mm, dyn. $R \geq 20$ mm

(S) = Beginning of the measuring length

S1, S2 = Switch signal

n = 1, 2, 3, ...

Permissible position deviation scanning head - tape scale [A|B]

Δ_Y = Displacement, ± 0.5 mm

Δ_Z = Gap tolerance, ± 0.2 mm

φ_Z = ± 1.00 mrad or $\pm 0.06^\circ$ (yaw angle)

φ_Y = ± 3.50 mrad or $\pm 0.20^\circ$ (pitch angle)

φ_X = ± 4.00 mrad or $\pm 0.23^\circ$ (roll angle)

mm

Tolerancing ISO 8015
ISO 2768:1989 - m H
< 6 mm: ± 0.2 mm

Mass (approx.)

- Version MK: 17 g/m
- Scanning head: 11.5 g
- Connector D-sub, 15-pin: 26.5 g
- + 30 g/m cable

Tape mounting tool **TMT MS 15 MK** (optional)

For safe and precise mounting of the steel tape scale.

- Mount TMT MS 15 MK instead of the MS 15 scanning head.
- Thread steel tape scale (version MK) and move along the scale length
- Remove TMT MS 15 MK, mount MS 15 scanning head.

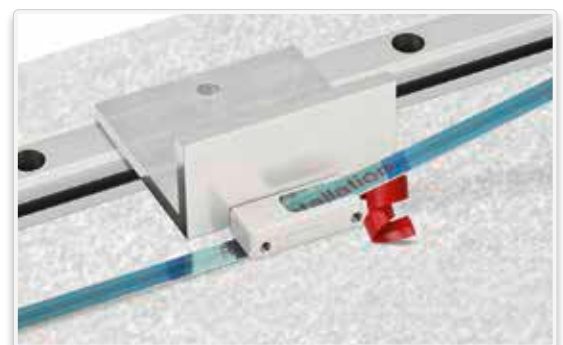

MS 15 MP

- Steel tape scale in aluminum carrier with clamping element
- Clamping element bolted
- Carrier with adhesive tape



Dimensions, mounting tolerances:

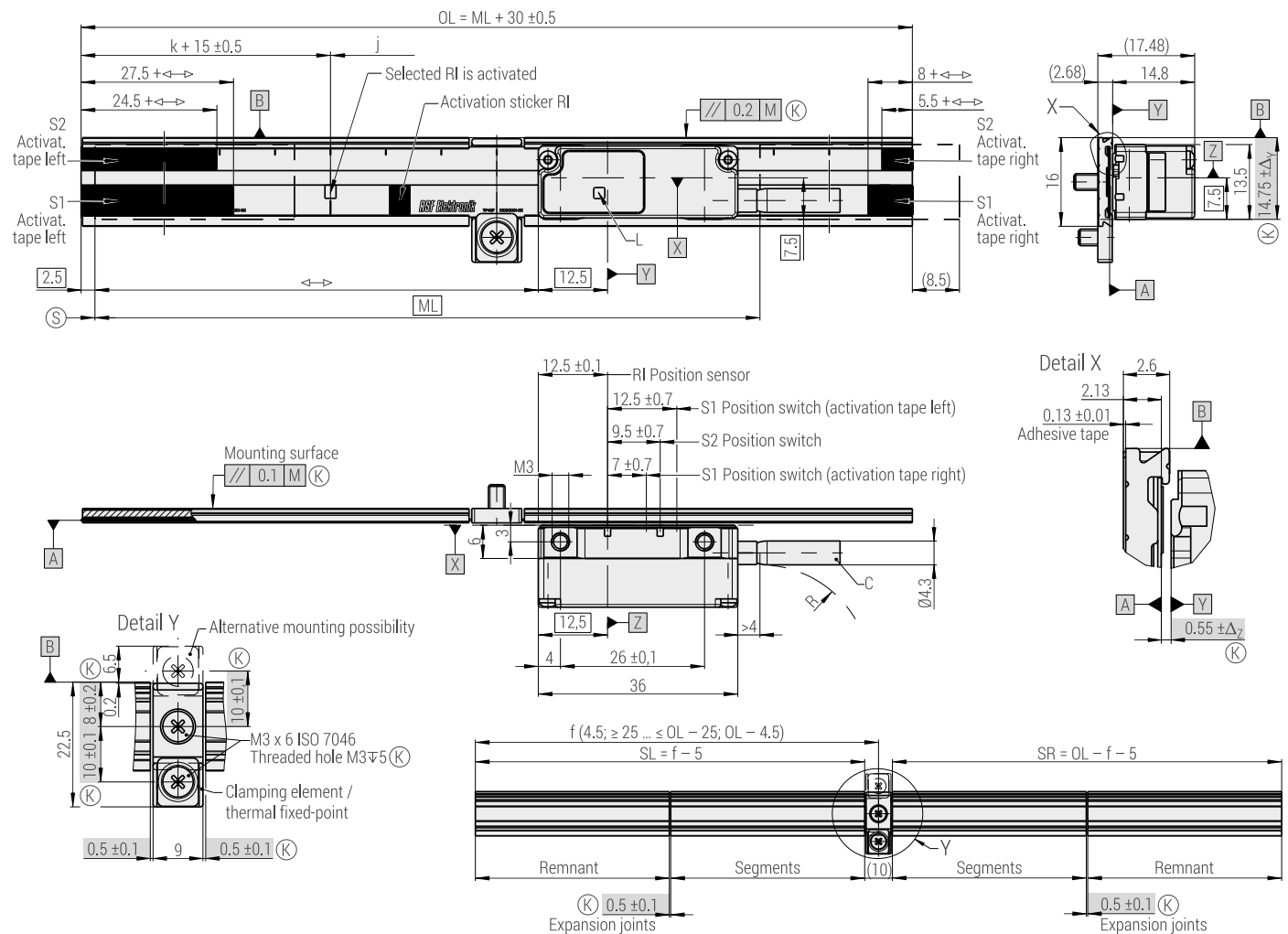

- M = Machine guideway
- ML = Measuring length
- OL = Overall length
- $\leftarrow \rightarrow$ = $0 \dots ML$
- RI = Selectable reference mark(s)
- k = Any position of the selected reference mark from the beginning of the ML
- j = Additional reference marks spaced every $n \times 50$
- f = Position of the clamping element
- Standard: $f = OL/2$
- Optional: $f = \begin{cases} 4.5 \\ \geq 25 \dots \leq OL - 25 \\ OL - 4.5 \end{cases}$
- C = Cable
- (K) = Required mating dimensions
- L = LED function control
- R = Bending radius: stat. $R \geq 8$ mm, dyn. $R \geq 20$ mm
- (S) = Beginning of the measuring length
- S1, S2 = Switch signal
- n = 1, 2, 3 ...

- Permissible position deviation scanning head - tape scale [A] [B]
- Δ_y = Displacement, ± 0.5 mm
 - Δ_z = Gap tolerance, ± 0.2 mm
 - φ_z = ± 1.00 mrad or $\pm 0.06^\circ$ (yaw angle)
 - φ_y = ± 3.50 mrad or $\pm 0.20^\circ$ (pitch angle)
 - φ_x = ± 4.00 mrad or $\pm 0.23^\circ$ (roll angle)

- Mass (approx.)
- Version MP: 90 g/m
 - + 15 g clamping element
 - Scanning head: 11.5 g
 - Connector D-sub, 15-pin: 26.5 g
 - + 30 g/m cable

mm

 Tolerancing ISO 8015
 ISO 2768:1989 - m H
 < 6 mm: ± 0.2 mm

MS 15 GK, BK

- GK: Glass scale with adhesive tape
- BK: Glass ceramic scale with adhesive tape



Dimensions, mounting tolerances:

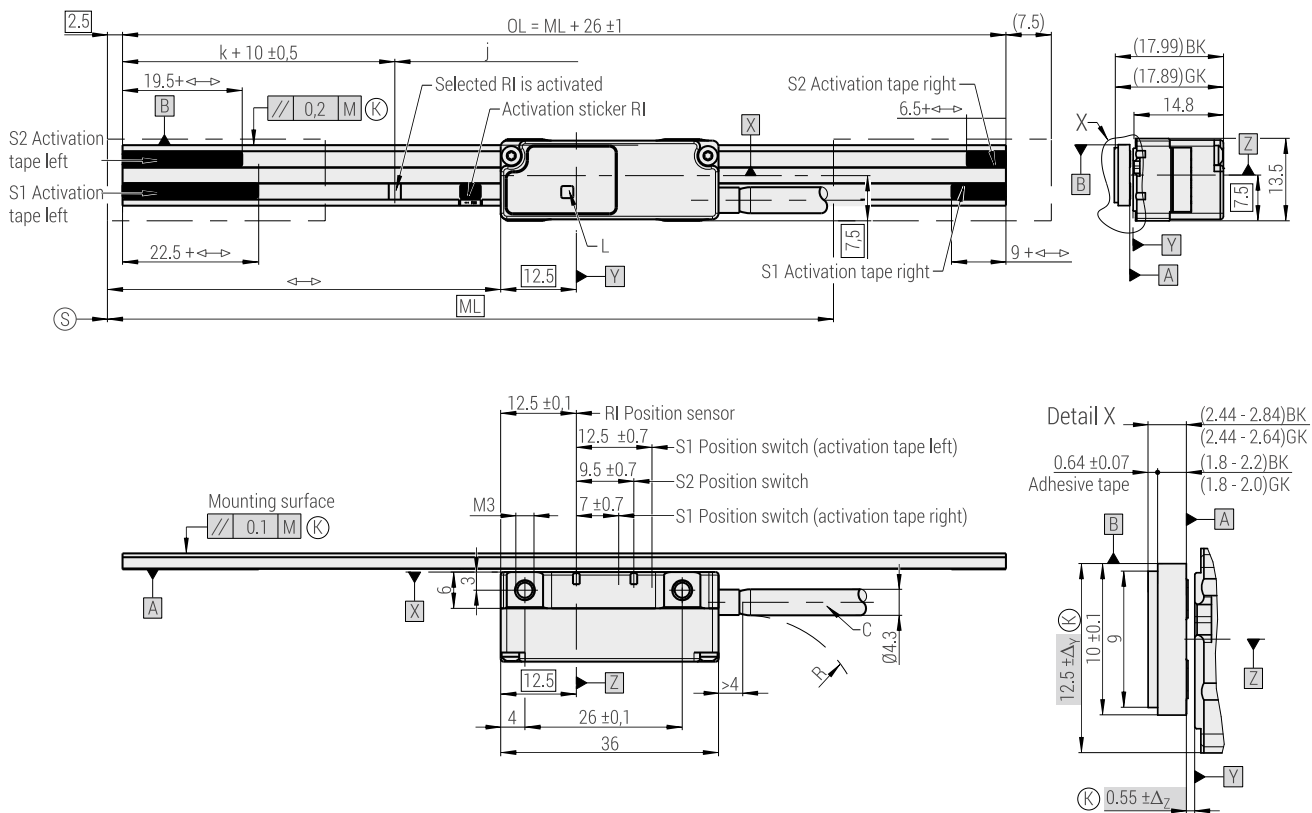

- M = Machine guideway
- ML = Measuring length
- OL = Overall length
- ↔ = 0...ML
- RI = Selectable reference mark(s)
- k = Any position of the selected reference mark from the beginning of the ML
- j = Additional reference marks spaced every n x 50
- C = Cable
- (K) = Required mating dimensions
- L = LED function control
- R = Bending radius: stat. R ≥ 8 mm, dyn. R ≥ 20 mm
- (S) = Beginning of the measuring length
- S1, S2 = Switch signal
- n = 1, 2, 3, ...
- BK = Glass ceramic scale with adhesive tape
- GK = Glass scale with adhesive tape

- Permissible position deviation scanning head – scale (A|B)
- Δ_y = Displacement, ±0.5 mm
 - Δ_z = Gap tolerance, ±0.2 mm
 - φ_z = ±1.00 mrad or ±0.06° (yaw angle)
 - φ_y = ±3.50 mrad or ±0.20° (pitch angle)
 - φ_x = ±4.00 mrad or ±0.23° (roll angle)

- Mass (approx.)
- Version BK: 57 g/m
 - Version GK: 55 g/m
- Scanning head: 11.5 g
Connector D-sub, 15-pin: 26.5 g
+ 30 g/m cable

mm
Tolerancing ISO 8015
ISO 2768:1989 – m H
< 6 mm: ±0.2 mm

REFERENCE MARK (RI)- AND SWITCH POINTS-SELECTION

Reference mark (RI)-selection

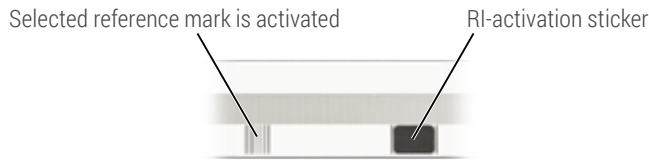

NOTE

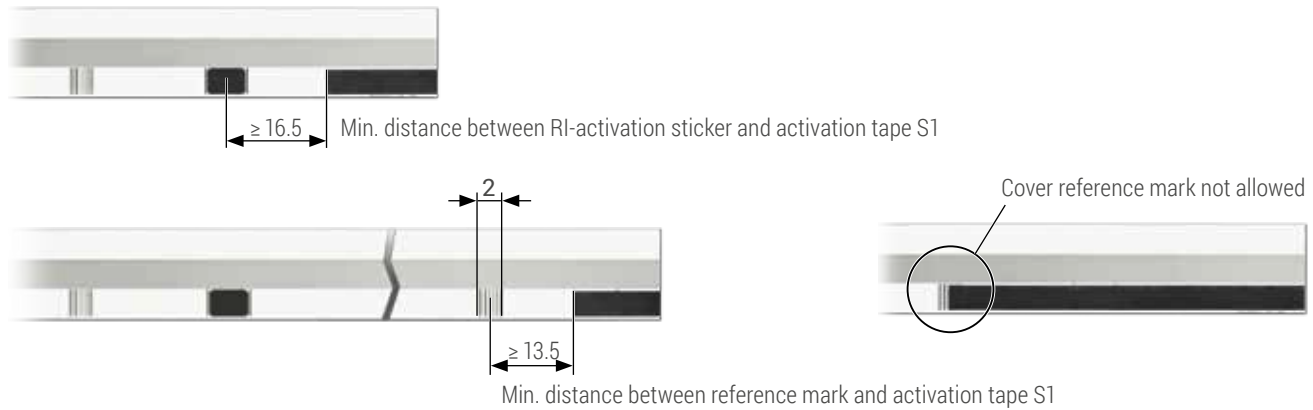

MS 15 BK, GK and MK selection of the switch points

S2 = Switch point signal S2 from beginning of ML

X2_L = Activation tape length

X2_L = S2 + 19.5

S1 = Switch point signal S1 before end of ML

X1_R = Activation tape length

X1_R = S1 + 9

EXAMPLE

S2: 20 mm from beginning of ML → X2_L = 39.5 mm

S1: 20 mm before end of ML → X1_R = 29 mm

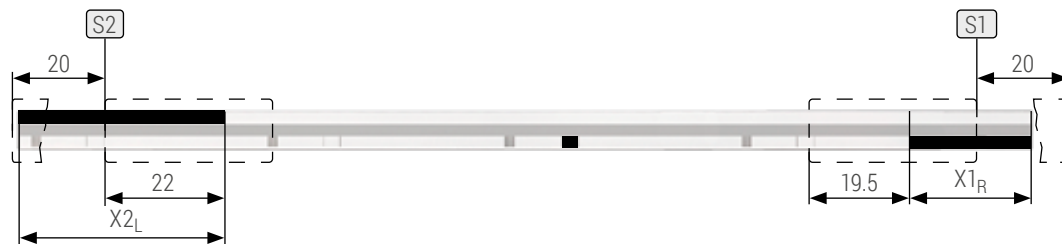

MS 15 MP selection of the switch points

S2 = Switch point signal S2 from beginning of ML

X2_L = Activation tape length

X2_L = S2 + 24.5

S1 = Switch point signal S1 before end of ML

X1_R = Activation tape length

X1_R = S1 + 8

EXAMPLE

S2: 80 mm from beginning of ML → X2_L = 104.5 mm

S1: 15 mm before end of ML → X1_R = 23 mm

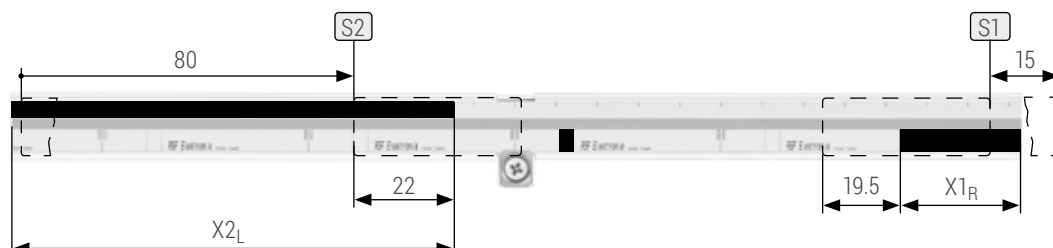

INSPECTION OF FUNCTIONS

STATUS OF LED	INFORMATION	NOTE
Without external test box		
Function-control main track		
▪ LED displays GREEN	Counting signals very good	After successful mounting
▪ LED blinks GREEN	Counting signals good	At mounting not allowed → allowed during operation
▪ LED blinks RED	Counting signals out of tolerance → error	Check mounting, clean graduation carrier
Function-control reference impulse RI		Only by passing the reference mark
▪ LED blinks BLUE	RI within tolerance	
▪ LED blinks RED	RI out of tolerance	Check mounting, clean graduation carrier
With external test box		
Function-control main track		
▪ LED displays GREEN	Scanning head supplied with power	Evaluation of counting signals via LED not active
Function-control reference impulse RI		Only by passing the reference mark
▪ LED blinks BLUE	RI within tolerance	
▪ LED blinks RED	RI out of tolerance	Check mounting, clean graduation carrier

Note! If the scanning head passes a further reference mark within 0.5 s the information of the reference mark will not be stated by the function control. Thus the information of the incremental signals will also be displayed at high traversing speed and/or many reference marks.

EXTERNAL TESTING DEVICE PWT 101

Even though the MS 15 linear encoders allow large mechanical mounting tolerances, it is recommended to control the function of counting signals and reference impulse.

The signals can be controlled directly via the integrated LED function-control or connected to an oscilloscope and checked for conformity with signal specifications. The last mentioned method requires some effort.

The PWT 101 is a testing device for checking the function and adjustment of RSF Elektronik encoders. At encoders with pin assignment according to RSF standard (compare page 05) the pinout adapter PA2 must be used additionally. At alternative pin assignments other pinout adapters could be necessary.

Thanks to its compact dimensions and robust design, the PWT 101 is ideal for mobile use. A 4.3-inch touchscreen provides for display and operation.

Available functions

The performance range of the PWT 101 can be expanded by firmware update. Appropriate firmware files that can be imported to the PWT 101 through a memory card (not included in delivery) will be made available at www.heidenhain.de.

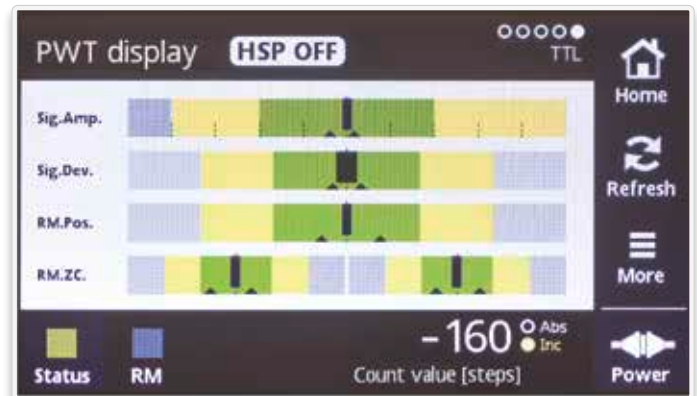

FURTHER PRODUCTS



MCR 15 | MCS 15

Absolute modular angle encoders with small dimensions

- Diverse serial interfaces
- Status display directly at the scanning head via LED function
- Easy mounting as a result of large mounting tolerances
- High insensitivity against contaminations
- Possible drum diameter (TTR): 50.00 mm to 350.23 mm (outside)
- Possible scanning diameter (MBR): 59.93 mm to 350.23 mm (outside)
- Steel tape scale (MSS) from \varnothing 75 mm



MSR 15 | MSS 15

Incremental modular angle encoders with small dimensions

- Quality of the scanning signals is directly visible at the scanning head via a tricolored LED function
- Easy mounting as a result of large mounting tolerances
- High insensitivity against contaminations
- Possible drum diameter (TTR): 50.00 mm to 350.23 mm (outside)
- Possible scanning diameter (MBR): 59.93 mm to 350.23 mm (outside)
- Steel tape scale (MSS) from \varnothing 75 mm



MSR 45

Modular angle encoders with steel tape scale - various versions

- Full-circle or segment version
- Grating period: 200 μ m
- Accuracy of the grating (stretched): \pm 30 μ m/m
- High permissible rotational speed resp. circumferential speed
- Integrated subdividing: up to times 100
- Possible diameter: Full-circle from \varnothing 146.99 mm Segment from \varnothing 150 mm



MC 15

Absolute linear encoders with status display

- Diverse serial interfaces
- Status display directly at the scanning head via LED function
- Easy mounting as a result of large mounting tolerances
- High insensitivity against contaminations
- Max. measuring length Steel tape scale: 10 000 mm



MS 25

Exposed linear encoder with and without integrated mounting control

- Easy mounting; no test box or oscilloscope needed
- Quality of the scanning signals is directly visible at the scanning head via a tricolored LED function
- Two independent switch tracks for individual special functions
- Position of reference mark selectable by customer
- High insensitivity against contamination
- High permissible traversing speed
- Integrated subdividing: up to times 200
- Max. measuring length Glass scale: 3140 mm Steel tape scale: 20 000 mm



MS 45

Exposed scanning linear encoders with integrated mounting control

- Easy mounting; no test box or oscilloscope needed
- Quality of the scanning signals is directly visible at the scanning head via a tricolored LED function
- Flat dimensions
- Easy mounting due to large mounting tolerances
- High insensitivity against contamination
- High permissible traversing speed
- Integrated subdividing: up to times 100
- Max. measuring length: Steel tape scale: 30 000 mm

DISTRIBUTION CONTACTS

AUSTRIA <i>Corporate Head Quarters</i>	RSF Elektronik Ges.m.b.H.	A-5121 Tarsdorf 93	☎ +43 62 78 81 92-0 FAX +43 62 78 81 92-79	e-mail: info@rsf.at internet: www.rsf.at
BELGIUM	HEIDENHAIN NV/SA	Pamelse Klei 47 1760 Roosdaal	☎ +32 (54) 34 3158 FAX +32 (54) 34 3173	e-mail: sales@heidenhain.be internet: www.heidenhain.be
FRANCE	HEIDENHAIN FRANCE sarl	2 Avenue de la Christallerie 92310 Sèvres	☎ +33 1 41 14 30 00 FAX +33 1 41 14 30 30	e-mail: info@heidenhain.fr internet: www.heidenhain.fr
GREAT BRITAIN	HEIDENHAIN (GB) Ltd.	200 London Road Burgess Hill West Sussex RH15 9RD	☎ +44 1444 247711 FAX +44 1444 870024	e-mail: sales@heidenhain.co.uk internet: www.heidenhain.co.uk
ITALY	HEIDENHAIN ITALIANA S.r.l.	Via Asiago, 14 20128 Milan	☎ +39 02 27075-1 FAX +39 02 27075-210	e-mail: info@heidenhain.it internet: www.heidenhain.it
NETHERLANDS	HEIDENHAIN NEDERLAND B.V.	Copernicuslaan 34 6716 BM EDE	☎ +31 318-581800 FAX +31 318-581870	e-mail: verkoop@heidenhain.nl internet: www.heidenhain.nl
SPAIN	FARRESA ELECTRONICA S.A	Les Corts 36-38 08028 Barcelona	☎ +34 93 4 092 491 FAX +34 93 3 395 117	e-mail: farresa@farresa.es internet: www.farresa.es
SWEDEN	HEIDENHAIN Scandinavia AB	Storsåtragränd 5 SE-12739 Skärholmen	☎ +46 8 531 933 50 FAX +46 8 531 933 77	e-mail: sales@heidenhain.se internet: www.heidenhain.se
SWITZERLAND	HEIDENHAIN (SCHWEIZ) AG	Vieristrasse 14 8603 Schwerzenbach	☎ +41 44 806 27 27 FAX +41 44 806 27 28	e-mail: verkauf@heidenhain.ch internet: www.heidenhain.ch
CHINA	DR. JOHANNES HEIDENHAIN (CHINA) Co., Ltd	Tian Wei San Jie, Area A, Beijing Tianzhu Airport Industrial Zone Shunyi District, Beijing 101312	☎ +86 10 80 42-0000	e-mail: sales@heidenhain.com.cn internet: www.heidenhain.com.cn
ISRAEL	MEDITAL Hi-Tech	36 Shacham St., P.O.Box 7772 4951729 Petach Tikva	☎ +972 0 3 923 33 23 FAX +972 0 3 923 16 66	e-mail: avi@medital.co.il internet: www.medital.co.il
JAPAN	HEIDENHAIN K.K.	Hulic Kojimachi Bldg., 9F 3-2 Kojimachi, Chiyoda-ku Tokyo, 102-0083	☎ +81 3 3234 7781 FAX +81 3 3262 2539	e-mail: sales@heidenhain.co.jp internet: www.heidenhain.co.jp
KOREA	HEIDENHAIN LTD.	75, Jeonpa-ro 24beon-gil, Manan-gu, Anyang-si 14087 Gyeonggi-do	☎ +82 31 380 5200 FAX +82 31 380 5250	e-mail: info@heidenhain.co.kr internet: www.rsfc.co.kr
SINGAPORE	HEIDENHAIN PACIFIC PTE LTD.	51, Ubi Crescent 408593 Singapore	☎ +65 67 49 32 38 FAX +65 67 49 39 22	e-mail: info@heidenhain.com.sg internet: www.heidenhain.com.sg
TAIWAN	HEIDENHAIN CO., LTD.	No. 29, 33rd Road; Taichung Industrial Park Taichung 40768	☎ +886 4 2358 89 77 FAX +886 4 2358 89 78	e-mail: info@heidenhain.tw internet: www.heidenhain.com.tw
USA	HEIDENHAIN CORPORATION	333 East State Parkway Schaumburg, IL 60173-5337	☎ +1 847 490 11 91	e-mail: info@heidenhain.com internet: www.rsfc.heidenhain.com

Date 05/2023 ■ Art. No.1118281-03 ■ Doc. No. D1118281-09-B-01 ■ Technical adjustments in reserve!



RSF Elektronik

Ges.m.b.H.

Linear and Angle Encoders
Precision Graduations

Certified acc. to
ISO 9001
ISO 14001

